



Mobile universal measurement device

## MRG 512-PRO PQ Flex

Supplementary description to the  
operation manual UMG 512-PRO

Janitza electronics GmbH  
Vor dem Polstück 6  
35633 Lahnau | Germany  
Support tel. +49 6441 9642-22  
www.janitza.com | info@janitza.com

**Janitza**<sup>®</sup>

## **Contents**

Safety information	3
Concerning this operation manual	4
Scope of supply - basic device	4
Connecting the measurement case	4
Reading out recordings	5
MRG 512-PRO PQ Flex views	5
Measurement transformer settings	6
Example connection - voltage measurement	7
Example connection - current measurement	7
Schematic diagram: MRG 512-PRO PQ Flex design	8
Technical data	9

## Safety information

Please read the operating instructions enclosed diligently, as well as all other publications that must be drawn upon for working with this measurement case and the accessories.

Observe all safety instructions and warnings. Failure to comply with the instructions can result in personal injuries and/or damage to the product.

The measurement case must only be operated by specialised personnel. Specialised personnel are persons, that based on their respective training and experience, are qualified to recognise risks and prevent potential dangers that can be caused by the operation or maintenance of the measurement case.

Check the measurement case, the measurement wires and accessory parts for any signs of damage before use. Check whether there are cracks in the plastic of any parts missing. Pay particular attention to the insulation of the wiring and connectors. Defective parts must be replaced immediately. Do not use if damaged!

Comply with all of the locally applicable and national safety regulations.

Use personal protective equipment (e.g. approved rubber gloves, face protection and protective clothing) in order to avoid electric shocks and burning injuries.

If the measurement case is not operated in accordance with the operation manual, protection is no longer ensured and hazards can be presented by the device!

Do not work with the device if the front plate has been removed. Otherwise, you may come into contact with hazardous voltages! It is not permitted to use the device with the front plate removed!



Do not use the measurement case in wet or moist environments or in the vicinity of explosive gases or vapours.

Use the measurement case only with the measurement wires and adapter supplier.

Exercise particular caution when connecting and removing the flexible current transformers and the gripping probes for the measured voltage. Ensure that the circuit to be measured is de-energised.

Keep your fingers behind the finger protectors on the gripping measurement probes.

Voltages and currents that are outside the permissible measurement range can destroy the device.

The input voltage shall not be higher than the rated voltage of the measurement device.

Disconnect the input signals before cleaning the measurement case.



The UMG 512-PRO is not suitable for measuring DC voltages.

Measured voltages and measured currents must derive from the same network. Voltages outside the rated range could destroy the measurement case.

Incorrect network settings can cause faults in the network.



### **Attention! Fatal hazard due to electrical energy:**

High voltage spikes that are dangerous to touch can occur on current transformers that are driven with open-circuit secondary windings! For this reason, never operate current transformers with open-circuit secondary windings!

First connect the current transformer lines to the corresponding measurement case inputs!

## Concerning this operation manual

This description and the operating instructions for the device are part of the product.

- Read this description and the operation manual through prior to using the device.
- Keep this description and the operation manual throughout the complete service life of the product and have them readily available for reference.

- Pass this description and the operation manual on to each subsequent owner or user of the product.
- In the event of questions that are not covered by this operation manual for the UMG 512-PRO, please contact the support department of Janitza electronics GmbH (Tel. no. +49 6441-9642-22).

This device must only be operated and repaired by specialised personnel.

## Scope of supply

Number	Article no.	Designation
1	5216905	MRG 512-PRO PQ Flex
1	-	Supplementary description MRG 512-PRO PQ
1	3303195	Operation manual UMG 512-PRO
1	1506900	Carry case
1	0802105	Mains connection cable
4	1011510	Voltage pickoffs with fuses, black (gripping probes)
1	1011511	Voltage pickoff with fuse, blue (gripping probe)
1	0801902	Voltage measurement set (brown, black, grey, red, blue)
4	1503608	Rogowski coil with connection cable and plug (ø 190 mm, L 600 mm)
1	0801505	Cross patch cable, CAT 5e
2	-	Connection cable with plug for residual current measurement, 3 m (Residual current transformer not included in the scope of deliverables)

## Connecting the measurement case

1. Connect the mains cable to the measurement case (1) and connect to 230 V / 50 Hz. Switch on the measurement case via the on/off switch (2). The "Mains OK" (3) and "Batt. OK" (4) LEDs illuminate.
2. Carry out basic settings on the UMG 512-PRO (5), e.g.
  - Voltage transformer / current transformer settings
  - Recording configuration or
  - RCM measurement (the transformer for RCM measurement is not included in the scope of deliverables). The settings can be implemented via the accompanying GridVis software or directly on the UMG 512-PRO (see the accompanying instructions for the UMG 512-PRO for this).
3. Set up the measurement transformer (6) - see "Measurement transformer configuration" chapter.
4. Connect measured voltage with the voltage tap-offs via the voltage inputs (7) or with the measurement lines included in the scope of deliverables. In doing so, observe the applicable safety regulations.
5. Connect current transformer coils (operating current (8) or residual current (9)) with the measurement case via the screw terminals.
6. Connect the current transformer coils to the consumer to be measured.
7. Measurement starts
8. After measurement is complete, switch the device off (2), disconnect from the object being measured and disconnect from the mains!

## Reading out recordings

If you wish to read out the measured data, connect the measurement case to a PC via the Ethernet connection (10). The read-out is implemented via the GridVis® software.

## MRG 512-PRO PQ Flex views

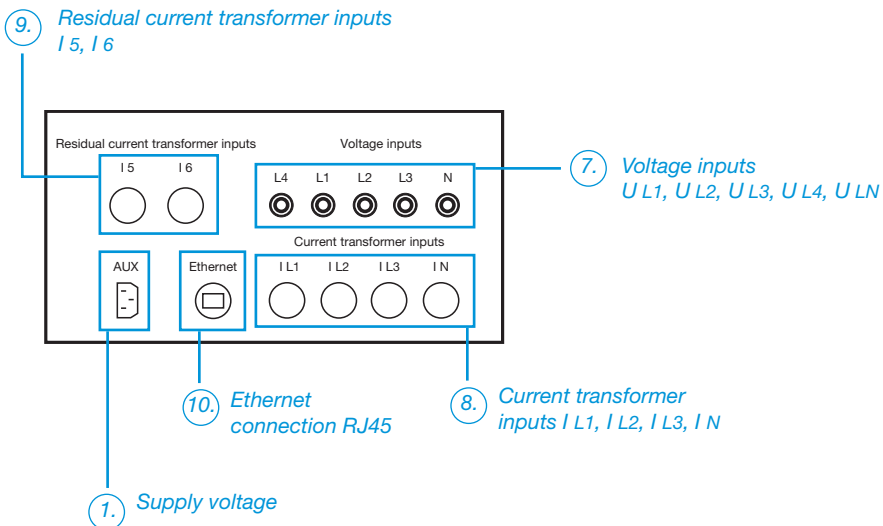
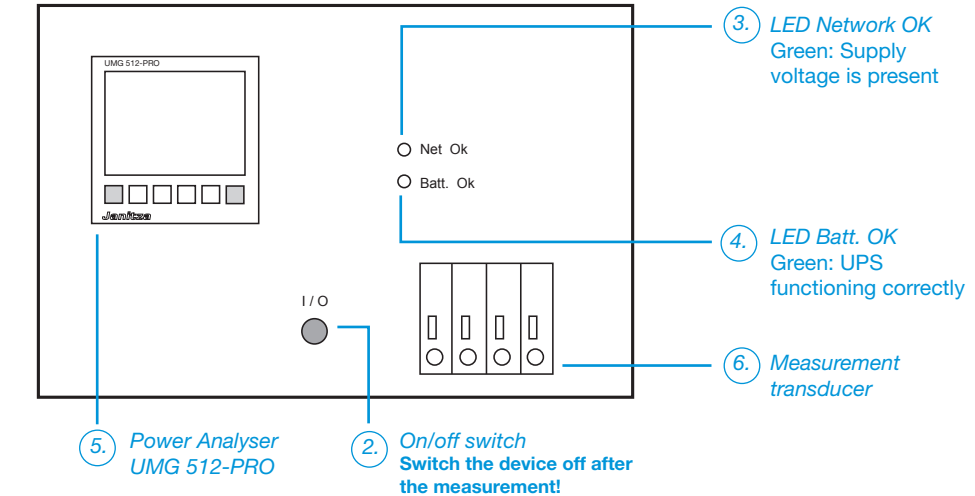

## Measurement transformer settings

Set the following parameters at the integrated measurement transducer:

- Compensate for the influence of the coil lengths through the potentiometer switching (1). To do so, set the parameters according to the table:

Setting	Rogowski coil
600 mm	Flex-CT-1A-600 mm

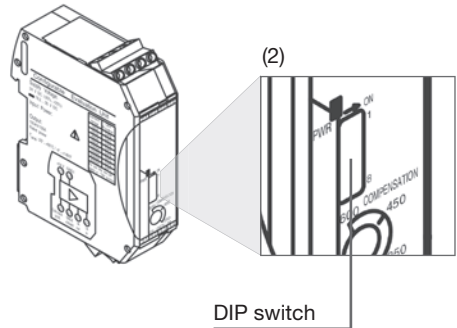
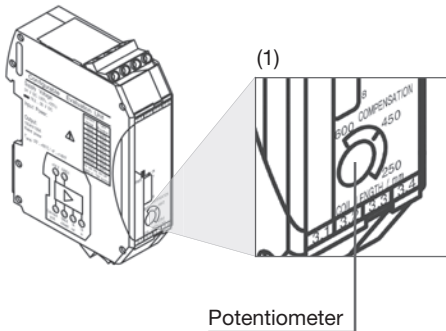

- The transformer ratio should be adapted in the UMG 512-PRO measurement device too in accordance with the table. Change the settings
  - by means of the GridVis software or
  - by entries on the device (measurement range: ratio  $\times 1 \text{ A}$ ). Please refer to the UMG 512-PRO operation manual for this.

- Set the current measurement range with the DIP switch (2) in accordance with the table:

Measurement range	DIP switch
100 A	8
250 A	7
400 A	6
630 A	5
1000 A	4
1500 A	3
2000 A	2
4000 A	1

**Example connection - voltage measurement**

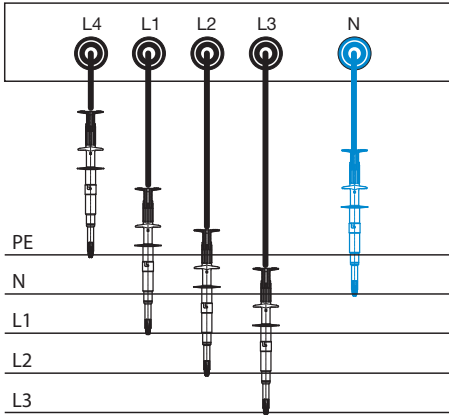

**Voltage pickoffs with fuse**

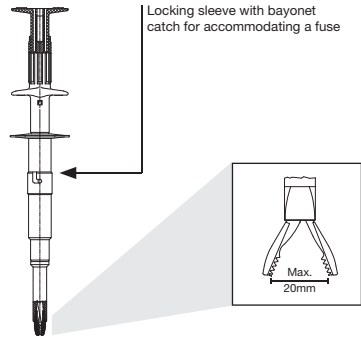

**Example connection - current measurement**

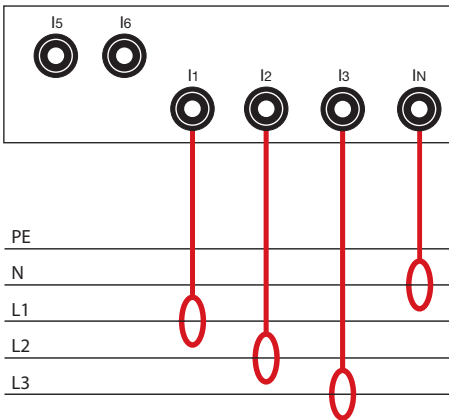

**Voltage measurement terms connections**



**Rogowski coil**



**RCM measurement cable**

Residual current transformer not included in the scope of deliverables



## Schematic diagram: MRG 512-PRO PQ Flex design



Settings, parametrisation and safety information apply in accordance with the installation and operating instructions enclosed.

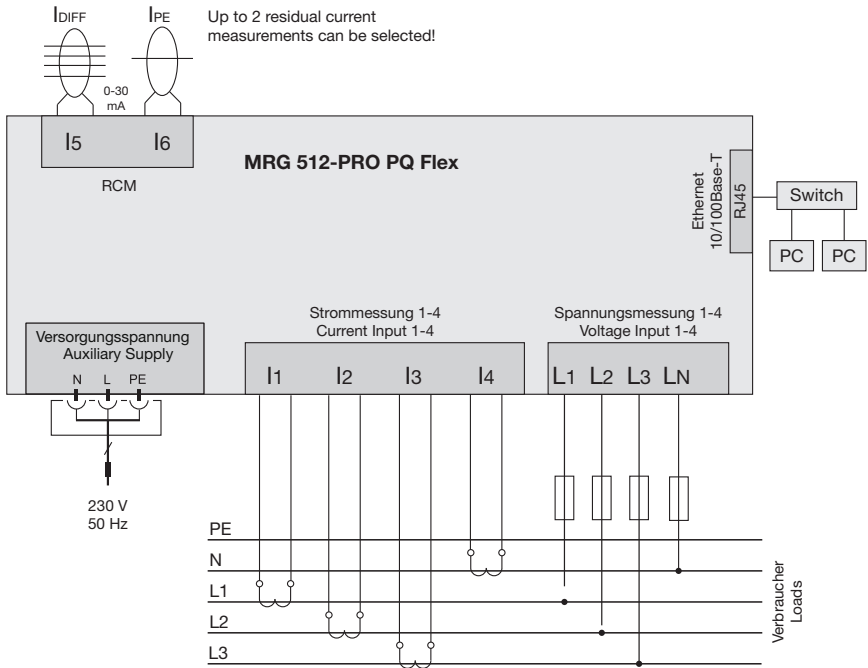

**Attention! Fatal hazard due to electrical energy:**

High voltage spikes that are dangerous to touch can occur on current transformers that are driven with open-circuit secondary windings! For this reason, never operate current transformers with open-circuit secondary windings!

First connect the current transformer lines to the corresponding measurement case inputs!



Please ensure the correct setting of the current transformer, check the performance values of the individual phases - these must not possess any negative signs when drawing energy. Also check the power factor for plausibility. Turn the current transformer if necessary!



## Technical data

Power supply	230 V, 50 Hz, 50 VA
Interface	Ethernet
Measurement inputs	See UMG 512-PRO operating instructions
Measurements	See UMG 512-PRO operating instructions
UPS buffering	Up to 3 h
Dimensions (L x W x H)	500 mm x 390 mm x 230 mm
Weight	14.2 kg